

LI1206H151R-10

UNCONTROLLED DOCUMENT

PHYSICAL DIMENSIONS:

A	3.20 [.126]	+ 0.20 [.008]
B	1.60 [.063]	+ 0.20 [.008]
C	1.10 [.043]	+ 0.20 [.008]
D	0.51 [.020]	+ 0.25 [.010]

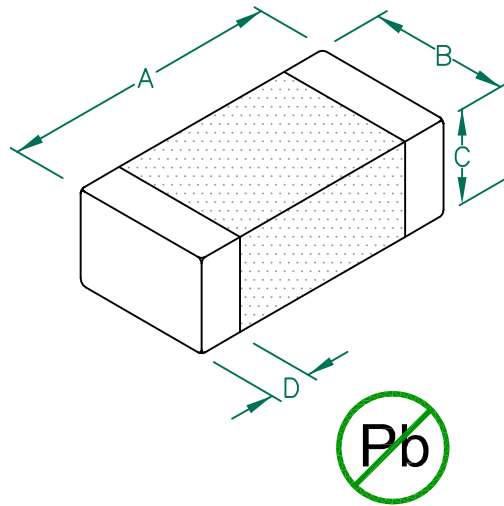

ELECTRICAL CHARACTERISTICS:

	Z @ 100MHz (Ω)	DCR (Ω)	Rated Current
Nominal	150		
Minimum	113		
Maximum	188	0.15	800 mA

- NOTES: UNLESS OTHERWISE SPECIFIED
1. TAPED AND REELED per CURRENT EIA SPECIFICATIONS 7" REELS, 3000 PCS/REEL.
 2. TERMINATION FINISH IS 100% TIN.
 3. COMPONENTS SHOULD BE ADEQUATELY PREHEATED BEFORE SOLDERING.
 4. OPERATING TEMP. RANGE: -40°C~+125°C. (INCLUDING SELF-HEATING)

Z vs FREQUENCY
IMPEDANCE UNDER DC BIAS

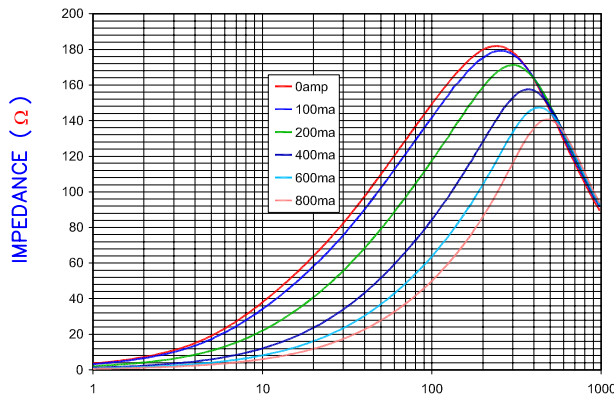

FREQUENCY (MHz)

|Z|, R, AND X vs. FREQUENCY

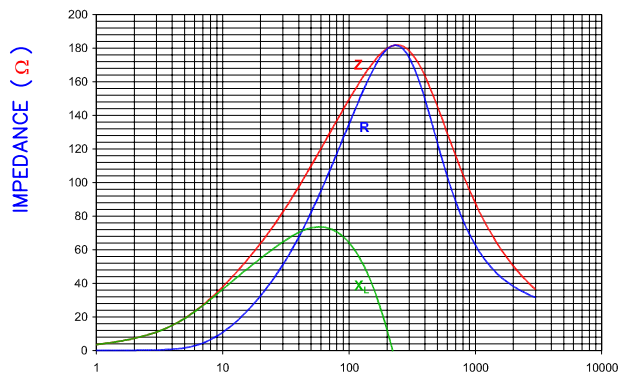

FREQUENCY (MHz)

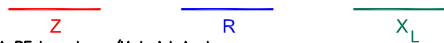

LAND PATTERNS FOR REFLOW SOLDERING

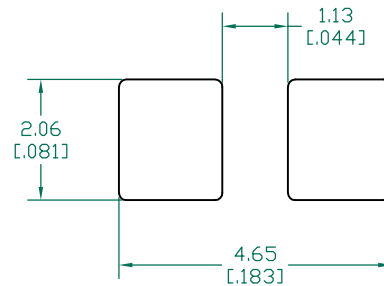

(For wave soldering, add 0.762 (.030) to this dimension)

RECOMMENDED SOLDERING CONDITIONS

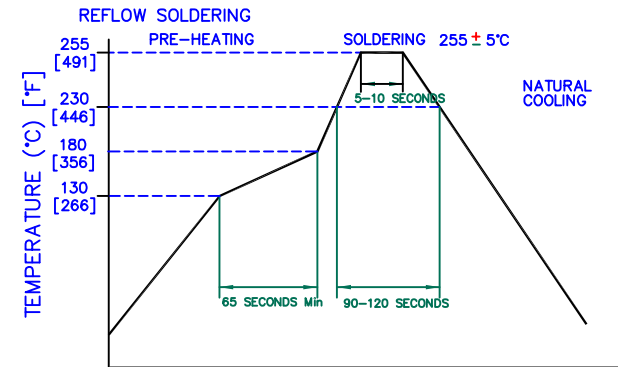

DIMENSIONS ARE IN mm [INCHES].

This print is the property of Laird Tech. and is loaned in confidence subject to return upon request and with the understanding that no copies shall be made without the written consent of Laird Tech. All rights to design or invention are reserved.



D	ADD OPERATING TEMPERATURE UPDATE LAIRD LOGO AND REFLOW CURVE	08/05/13	QU	PROJECT/PART NUMBER: LI1206H151R-10	REV D	PART TYPE: CO-FIRE	DRAWN BY: TMB
C	UPDATE COMPANY LOGO	07/22/08	JRK				
B	CORRECT REF # FROM 3289 TO 3298	07/22/05	JRK	DATE: 04/05/04	SCALE: NTS		SHEET: 2 of 2
A	ORIGINAL DRAFT	04/05/04	TMB	CAD # LI1206H151R-10-D	TOOL # -		
REV	DESCRIPTION	DATE	INT				

