

© COPYRIGHT 1975 BY AMP INCORPORATED, HARRISBURG, PA.
 ALL INTERNATIONAL RIGHTS RESERVED. AMP INCORPORATED PRODUCTS
 COVERED BY U. S. AND FOREIGN PATENTS AND/OR PATENTS PENDING.

REVISIONS						
P	F	ZONE	LTR	DESCRIPTION	DATE	APPROVED
✓		0		NPS 74-0542	RCH	10-20-75
✓		A		REV U-1037	DP	9/24/78
		B		ECN 850727		7-78
✓		C		ECN 1-12-90		1-90
		D		REV 0720-0856-96		6/96

UNPUBLISHED COPY NO. 10
 REPRODUCED NOR PUBLISHED
 WITHOUT WRITTEN PERMISSION
 OF AMP INCORPORATED.

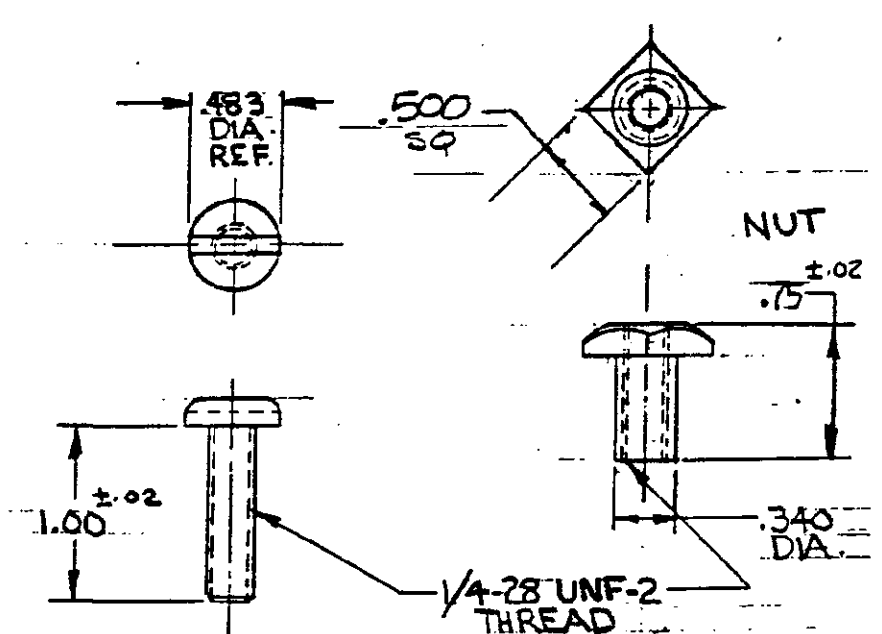
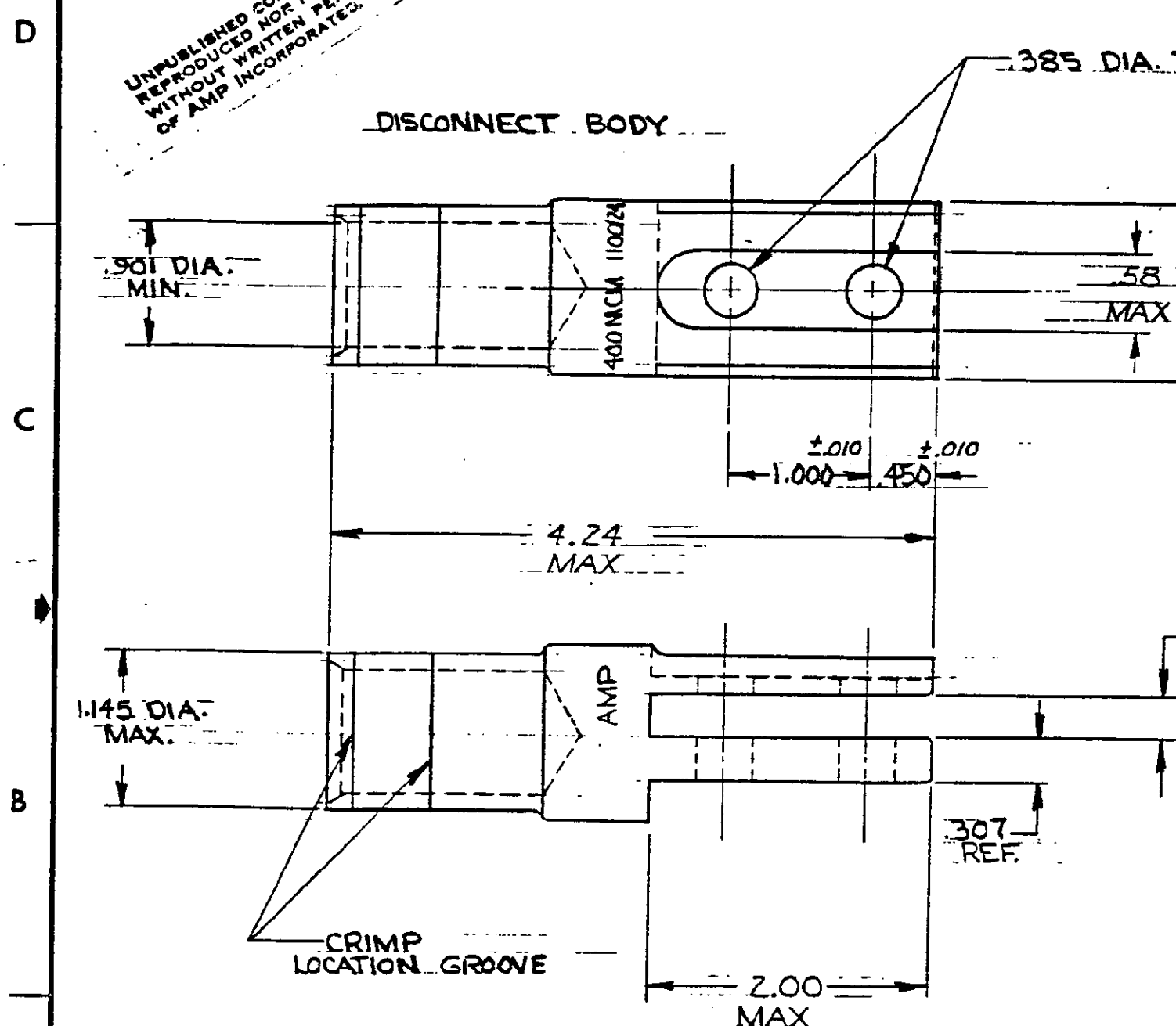

SCREW,
 PAN HEAD
 (ASA B18.6.3-1962)

NOTE:
 1. ASSEMBLY CONSISTS OF ONE (1)
 EACH DISCONNECT BODY, SCREW, & NUT

DISCONNECT BODY: BRASS (QQ-B-626)		NUT: STEEL (QQ-S-631 OR 634) OR BRASS (QQ-B-626)		53661-1
TIN PLATED (MIL-T-10727)		SCREW: STEEL, TIN PLATED (MIL-T-10727)		
MATERIAL & FINISH				PART NO.
UNLESS OTHERWISE SPECIFIED DIMENSIONS ARE IN INCHES. TOLERANCES ON: DECIMALS ±.008 ANGLES ±5°	CONTRACT NO	AMP INCORPORATED Harrisburg, Pa.		
	DR			
MATERIAL	CHK	NAME		
SEE ABOVE	Abel 10-20-75	WIRE TERMINAL AMPPOWER DISCONNECT - BOLTED WIRE SIZE: 400 MCM		
FINISH	APPD	SIZE	CODE IDENT NO	DRAWING NO
	SEE ABOVE	APPD	B	00779
	DSGN APPD	SCALE	SHEET	
	R. Hoffman 10/3/75	1:1	1 of 1	
	OTHER APPD			
	Abel 10-20-75			